



Examples LWA-90 with the illumination colour red, any customer specific text or graphics can be selected.

LED illuminated display with super bright LEDs or NEW: ultra bright with 2,5 times luminosity
For wall mounting or NEW: with provision and wire suspension for ceiling mounting

Profile housing made of aluminium with a printed front plate and two end caps. The transparent tinted front plate is printing by silk screen or foil on its back with the specific text. The illumination area is homogenous due to usage of a light stray body, activated by superbright LED-strips with constant current drivers. The LED illuminated display does not need any maintenance.

Via a first selector switch the indication unit can be set to either constant or flashing lightning. An integrated buzzer (~70dB) can be activated by a second selector switch. Optional, an intermitting relay-contact output (max. 1A/24Vdc) is available to drive an external sounder (24Vdc).

Options: (a) protection roof, made of stainless steel; (b) pre-mounting socket, made of stainless steel; (c) sealing set (IP54), (d) weather protection housing (IP65) for outdoor installation, made of transparent acrylic.

Technical data:

LWA-90 super bright (VdS)

LWA-90UH ultra bright

colour of housing:	black, white or white-aluminium	black, white or white-aluminium
colour of illumination:	red, yellow, green, (blue on request)	red
dimensions (W x H x D) :	300 x 120 x 35 mm	300 x 120 x 35 mm
illuminated area (W x H) :	240 x 90 mm	240 x 90 mm
supply voltage:	19 - 29 Vdc	21-29 Vdc
supply current @24Vdc constant :	75 mA (red,yellow); 126 mA (green)	150 mA
supply current for buzzer	+ 12 mA	+ 12 mA
supply current for optional relay	+ 10 mA	+ 10 mA
self-resetting fuse:	polyswitch	polyswitch

protection class: IP 50; dust proof; (VdS): -20° .. +40°C (typical): -40° .. +85°C
 option: sealing profiles IP54, transparent weather protection housing according to IP65

Mounting:

solder pins parallel to +24V / GND for end-of-line resistor; ext. decoupling diode is not necessary
 connector terminals, doubled for coming and going cables

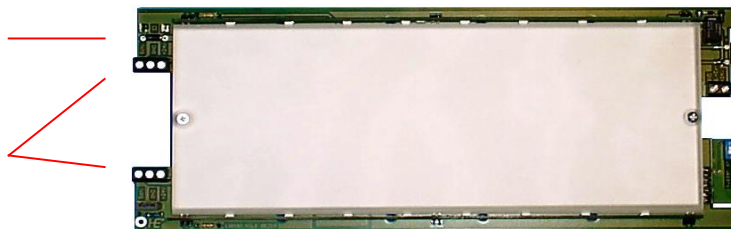

buzzer
 (optional) output 24Vdc for external sounder
 DIP-switch 1: constant / flashing
 DIP-switch 2: buzzer ON / OFF

Profile housing with two end caps ABS: left 2 holes Ø 18.5 mm with lock plugs, right without holes

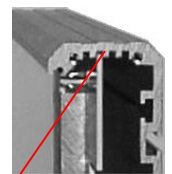
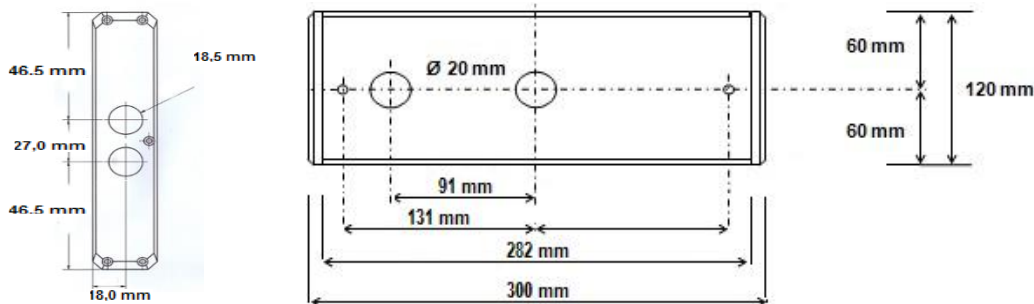

4. Slot

- The profile housing is fixed by 2 screws to the wall or to the mounting socket (M5x10). The cable entry can be done through the hole from behind or through one of the end caps.
- The board is inserted **in the 4rd slot from the bottom (right picture)**, the terminals are on the left hand side.
- Supply cable cores (+/-24Vdc) and shielding wire are connected to the screw terminals.
- Set the DIP-switches on the right hand side. Factory setting is: "flashing" and "buzzer OFF"
- Slide the front plate without the protective folio into the top slot of the housing.

(Attention: When using the sealing profiles slide the front plate with its rounded edges forwards carefully into the top slot of the housing, to avoid damaging the sealing profiles; ensure that the text is readable. For side cable entry PG11 cable glands are supplied to be used).

- End caps are plugged on the profile and secured with the screws at each end.
- Cleaning is done with a damp cloth only. Avoid any aggressive or abrasive cleaners.

The ceiling mount instructions are enclosed to the respective LED illuminated display.

